



This manual contains basic information, drawings and guides for installing the Polysand Roof Tile System on a basic type structure. This manual is a summary of good roofing practices and some of the industry standards that have been developed over time and is upgraded periodically. We stress the fact that we are not familiar with all building codes that pertain to roofing. Consequently, the general contractor, roofing contractor, installer or homeowner must accept responsibility for ensuring that the installation meets applicable building and roofing codes.

Please visit our website for additional information and contacts.

www.polysand.ca

Green technologies.

At Polysand, we consciously contribute to a cleaner environment by recycling used plastic. We collect, separate and remanufacture polymers to make all our products, which are absolutely safe for you and for the environment. We are proud to use green technologies that help conserve our planet's resources.

Installation Guide is subject to change without notice. Please check our website for the latest edition.

Technical data.

Mid-Profile Roman Tile

weight 1 pc.	3.9 lb (1.78 kg)
size	12.2" x 15.35" (310 x 390 mm)
wave height	1.77" (45 mm)
headlap	from 2" (50 mm)
lock overlap	0.8" (20 mm)
1 square (100 sq ft)	100 tiles (with 3" headlap)
1 square weight	390 lb (178 kg)

Ridge

weight, 1pcs.	3.6 lb (1.65 kg)
size	12.2" x 8.66"(310 x 220 mm)
height, side A	4" (102 mm)
height, side B	4.21" (107 mm)
headlap	0.8" (20 mm)
quantity per 10 ft	~10 pcs.

Tile Packaging

1 bundle	10 tiles / 39 lb
Bundles per pallet	45 bundles
Squares per pallet	4.5 squares
Weight of 1 pallet	1755 lb (800 kg)

Underlayment:

Because of the long service life of Polysand roofing tiles, a long-lasting underlayment should be used. Synthetic underlayment or #30 asphalt-saturated felt with 2" (50mm) headlap and 6" (150mm) at end laps is required as minimum underlayment on all tile roof applications. An ice dam protection should be used where required.

Nails/Screws:

Each tile should be fastened with two corrosion resistant nails/screws meeting code approval equal of 1½" inches with battens installed or 2" with no battens installed or sufficient length to properly penetrate ¾" into or through the thickness of the deck or batten. Copper, stainless steel or hot-dipped zinc coated nails are recommended to be used. Ring shank nails are preferable.

Roof Tile Layout:

A minimum 3-inch headlap must be maintained for all tiles. No sealant is necessary for the side lock of the tile.

Roof Slope Requirements:

Polysand roofing tiles can be installed on minimum slope of 4:12 (15 degrees). On extremely steep roofs above 19:12 or on vertical applications, wind currents may cause tiles to rattle. To avoid this, use wind clips on each tile along with a construction grade silicone sealant or other approved sealant.

Tile installation:

Tiles with projecting head lugs can be installed either directly on the deck or with the lugs fitting over battens nailed horizontally across the roof. Roof tile battens are typically nominal 1x2 or 1x4 lumber.

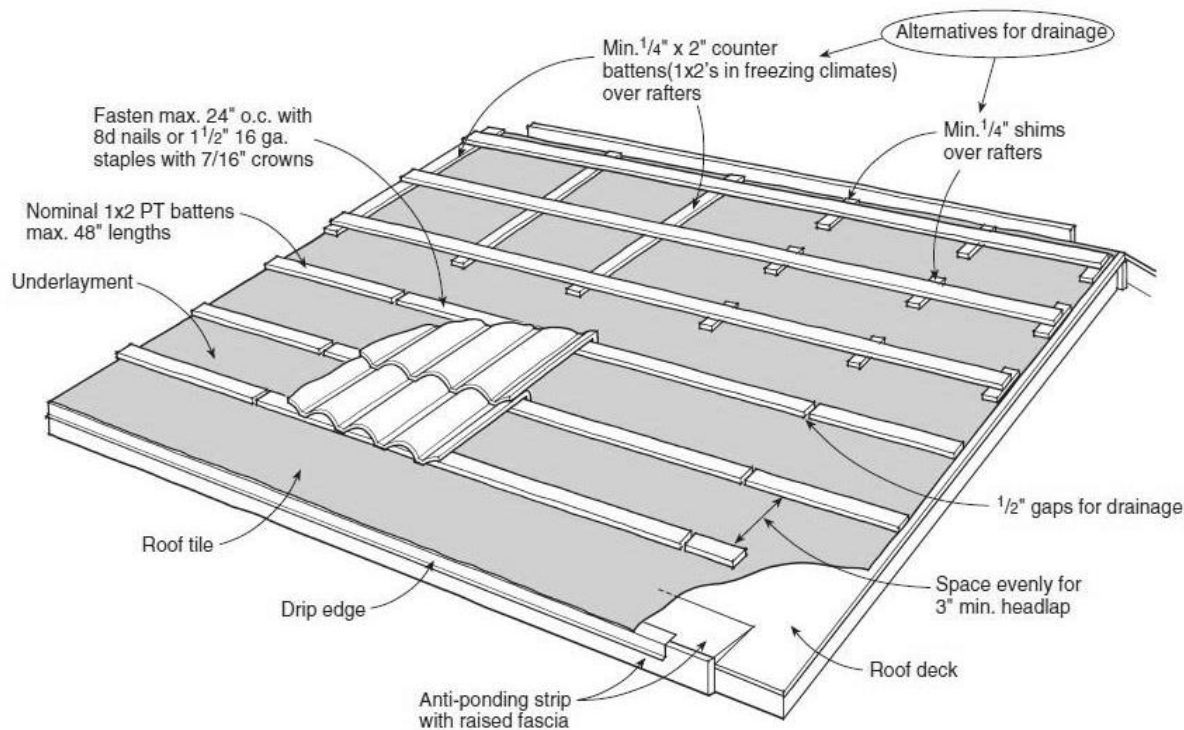

Horizontal battens are recommended for tiles with projecting head lugs on roof slopes greater than 7:12. Battens are also used on low slopes to minimize penetration of the underlayment. Vertical counter-battens are recommended to promote drainage on low slopes and in regions with high snowfall.

If using wood battens they shall be nominal 1"x2"x 8' or 1"x4"x8' (4 cm x 5 cm x 2.5 m) pressure-treated wood battens with drainage notches or ports 16" (40 cm) on center. On the roof with 8/12 slope or less

it is possible to install Polysand Roman tiles with no strapping. Please contact Polysand if you have questions.

Roof Layout

To install the battens, strike the lines on each of the hip. Strike the horizontal line at 14" (35.5 cm) (15" (38 cm) for direct to deck) for the top edge of the eave batten above the eave edge. Then, strike the horizontal line for the top edge of the top batten 1" (2.54 cm) (1/4" (6.35 mm) for direct to deck) down from the ridge center line. Then divide the distance between these two lines into equal increments, not to exceed 12.5" (32 cm) and strike lines for the top edges of the battens.

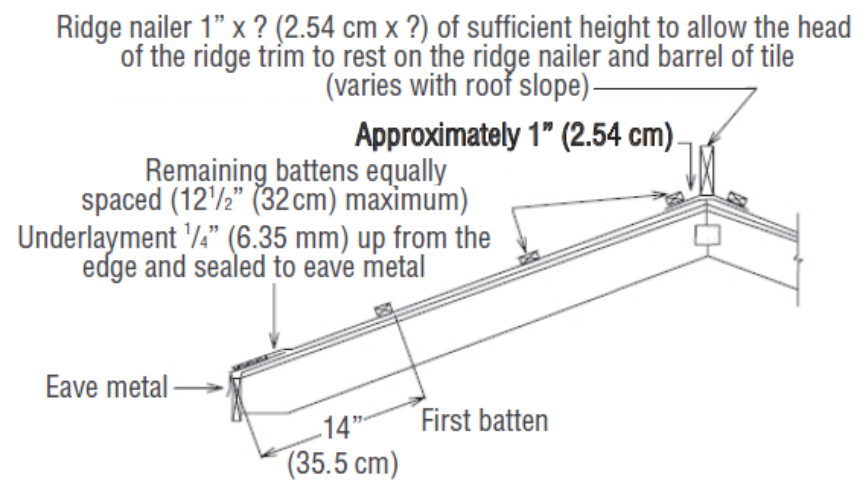

If different eave heights on the same roof plane do not allow for equal spacing, lay out the largest area as described above. On the smaller area, snap the eave line at the proper eave spacing and align the remaining lines with those already established on the larger roof plane. The results may reduce the spacing between the first and second lines of the small roof area, reducing the exposure of the bottom row of the tiles. If different ridge heights do not allow for equal spacing, add a short row along the shortest ridge. If a short row is required, cut the head off the tile piece and install a batten along the ridge so the short row maintains the same slope as the rest of the tiles.

Eaves:

Tiles need special treatment at the eaves to raise the bottom edge of the first tile to the correct height and to close off any openings to birds and insects.

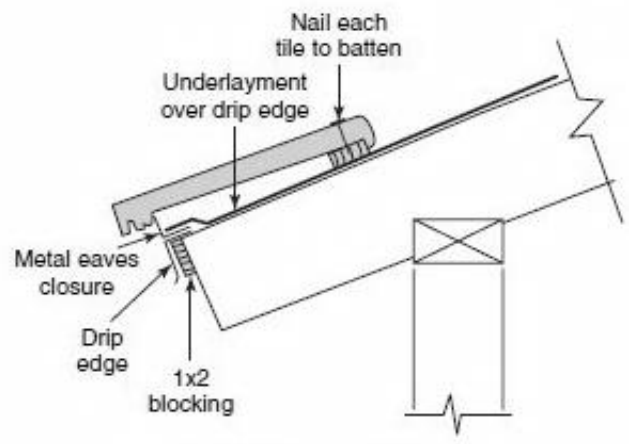

Ventelated eave:

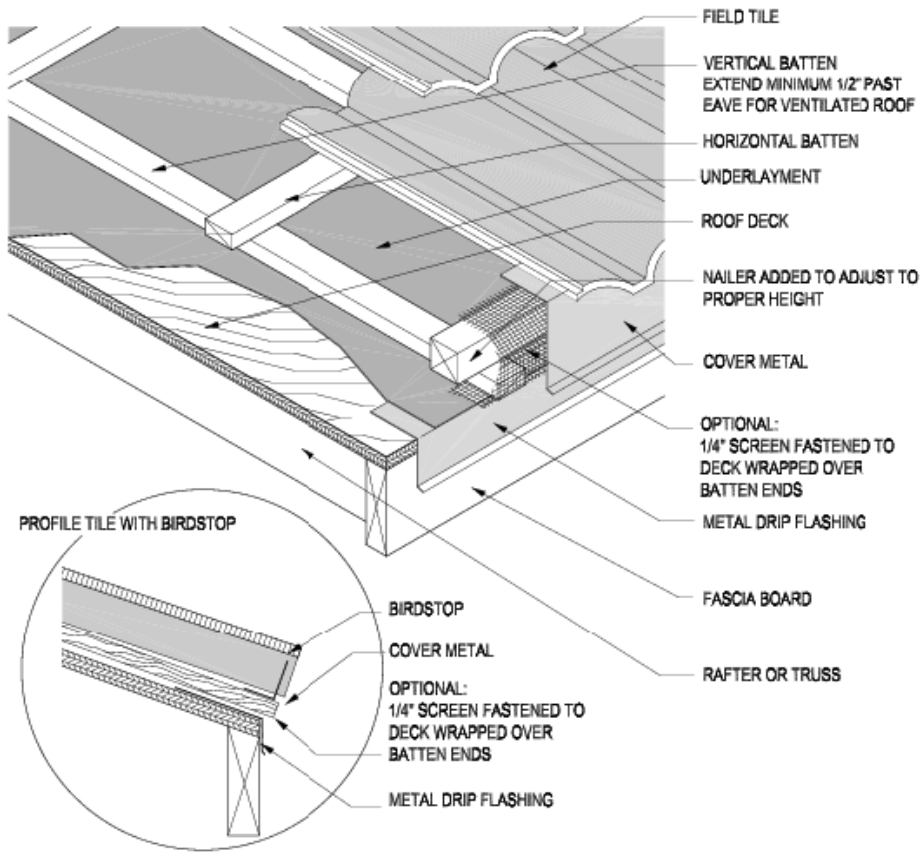

Hips and ridge:

The hip and ridge boards are typically 2"x3" to 2"x6" set on edge to hold the trim tiles in an even plane.

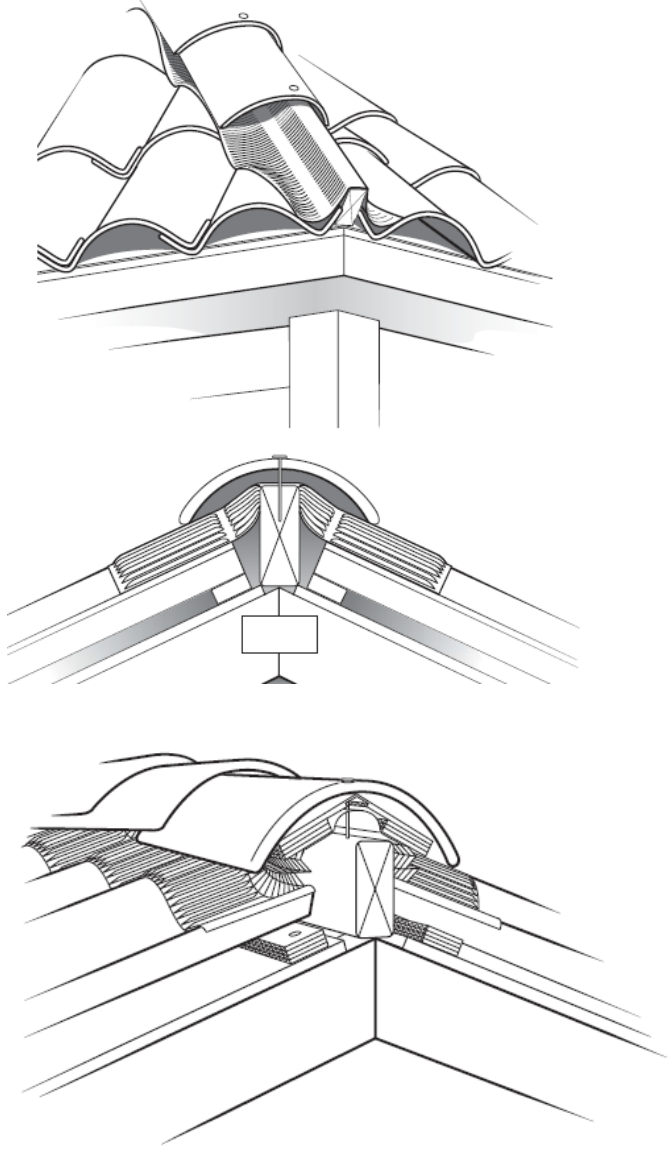

Open valley flashing:

When installing valley flashing, cut tile must be adequately secured not to drop down into the valley.

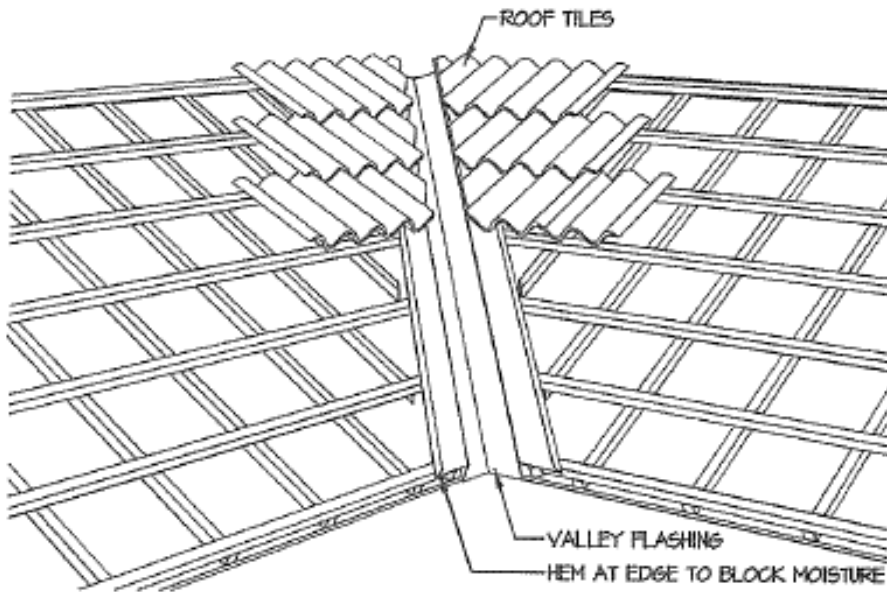

View at end of valley:

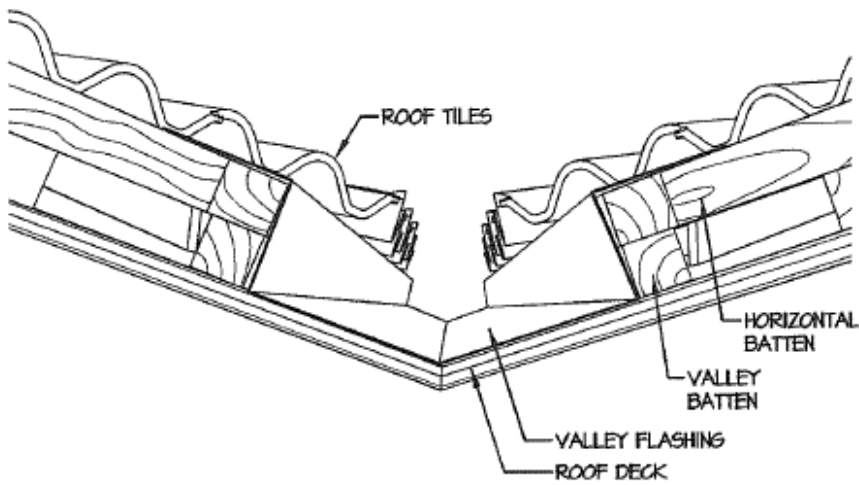

Closed valley with “W W” flashing:

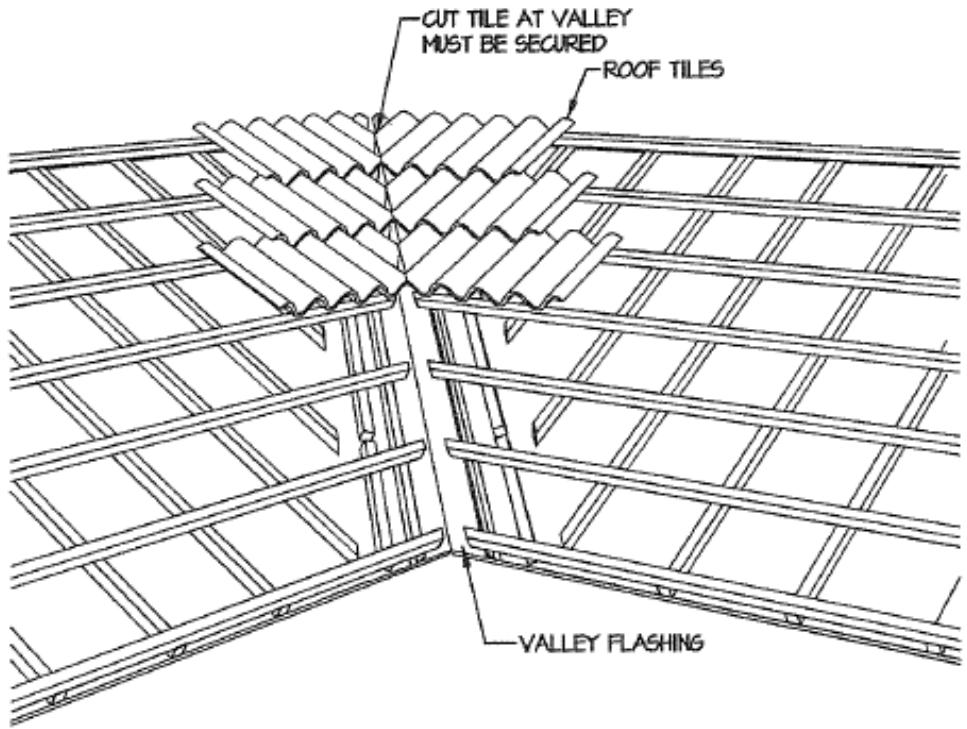

View at end of closed valley:

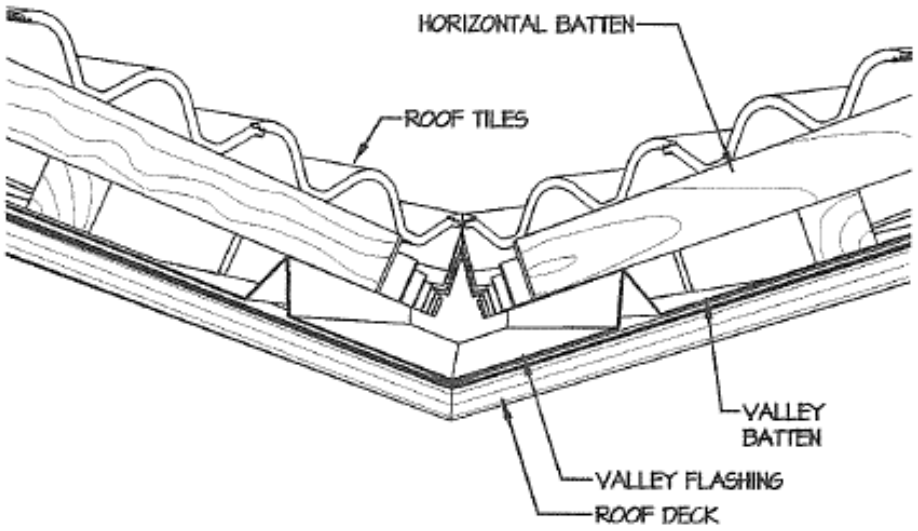

Valley transition:

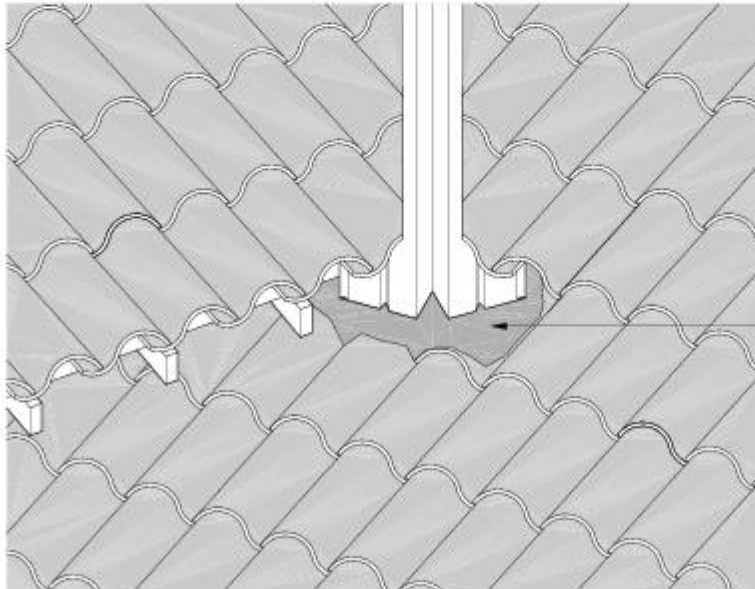

THE VALLEY MUST LAP ONTO THE TILE OF THE COURSE BELOW THE ROOF TRANSITION

LEAD SOAKER OR OTHER MALLEABLE METAL BE USED TO FORM A TRANSITION

Skylite flashing:

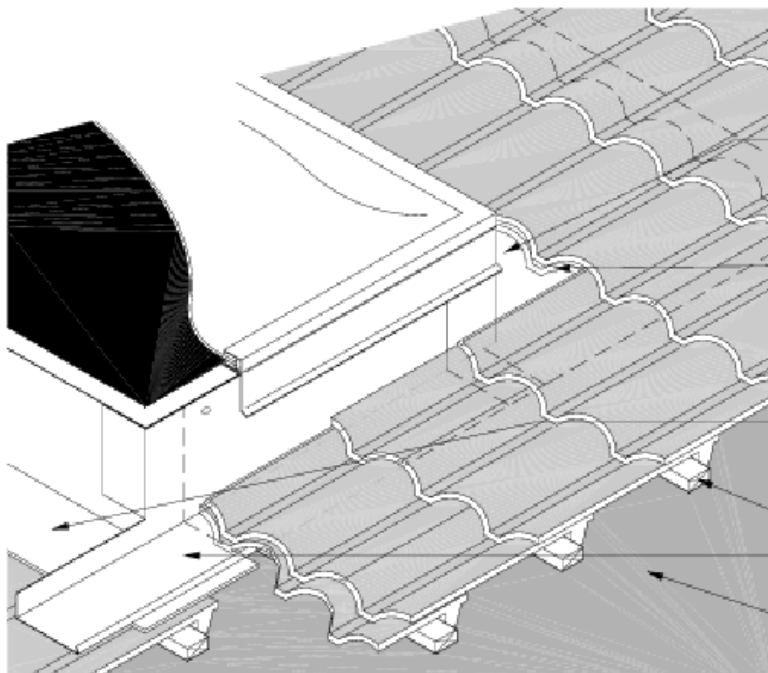

SADDLE OR CRICKET FLASHING

TILE NO CLOSER THAN 1" TO BACK OR SIDE OF SKYLIGHT

APRON FLASHING WITH WEATHER BLOCKING FOR PROFILE TILES

BATTENS OPTIONAL

PAN OR CHANNEL FLASHING

UNDERLAYMENT

OPTIONAL HEMMED EDGES

APRON FLASHING

PAN OR CHANNEL FLASHING

BACKER FLASHING

(SHOP FORMED FLASHING WITH SOLDERED OR SEALED CORNERS)

Angle flashing:

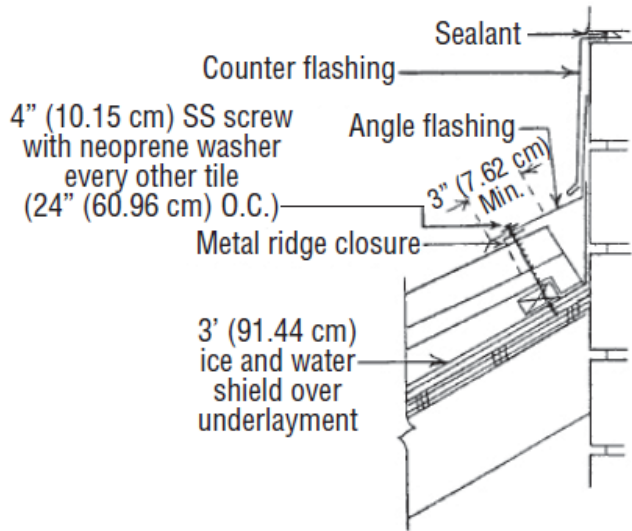

Rake flashing:

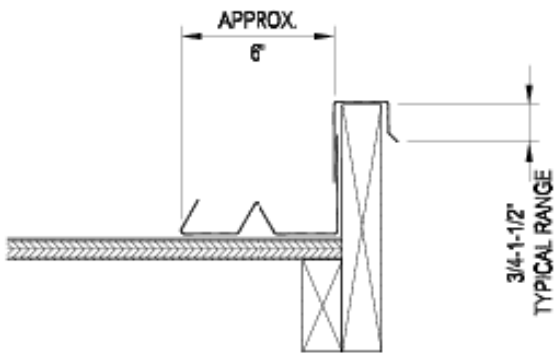
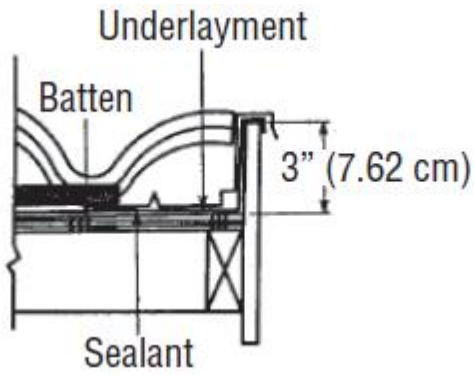

2 PIECE METAL PAN FLASHING WITH DRIP EDGE

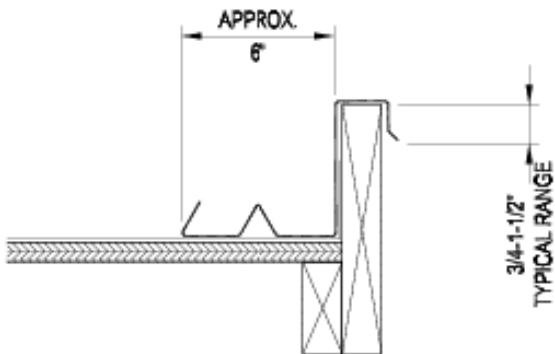

METAL PAN FLASHING WITH DRIP EDGE



OPTIONAL CLEAT DRIP EDGE

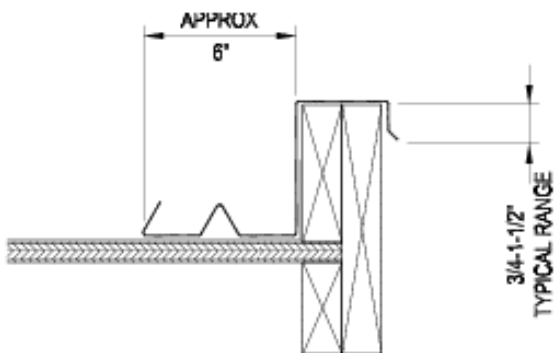

METAL PAN FLASHING WITH DRIP EDGE

Roof to wall flashing:

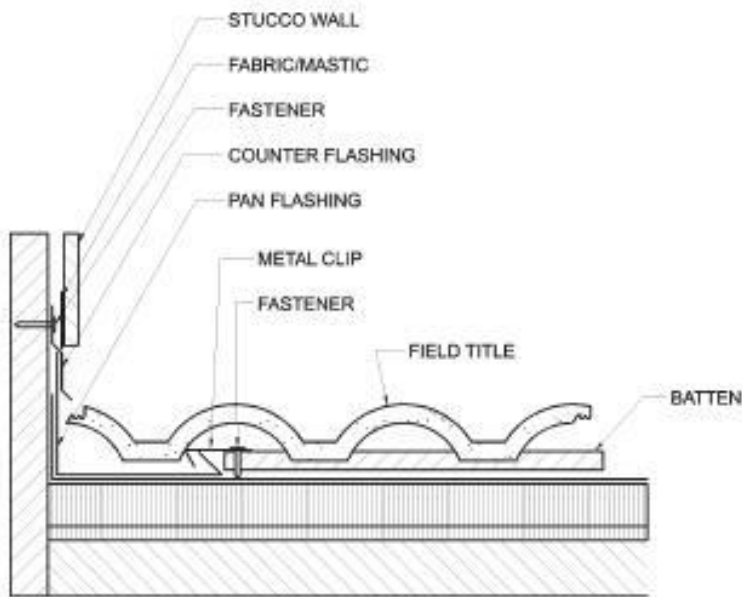
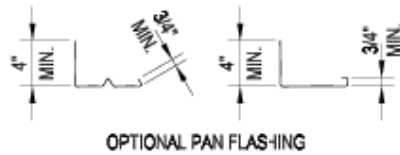
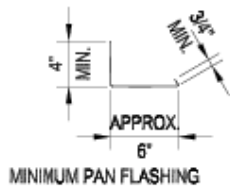
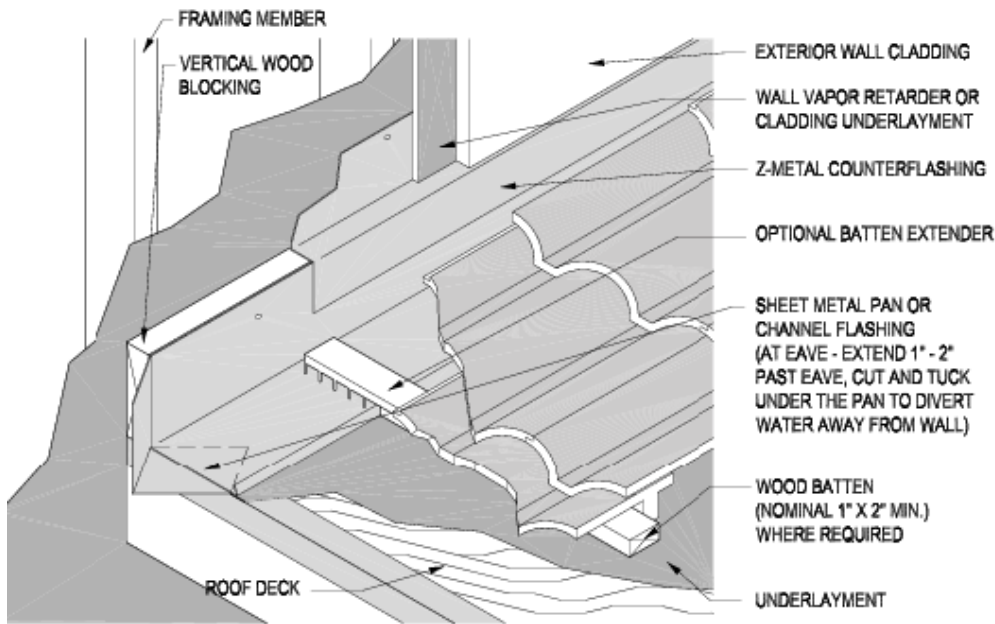

Gutter:

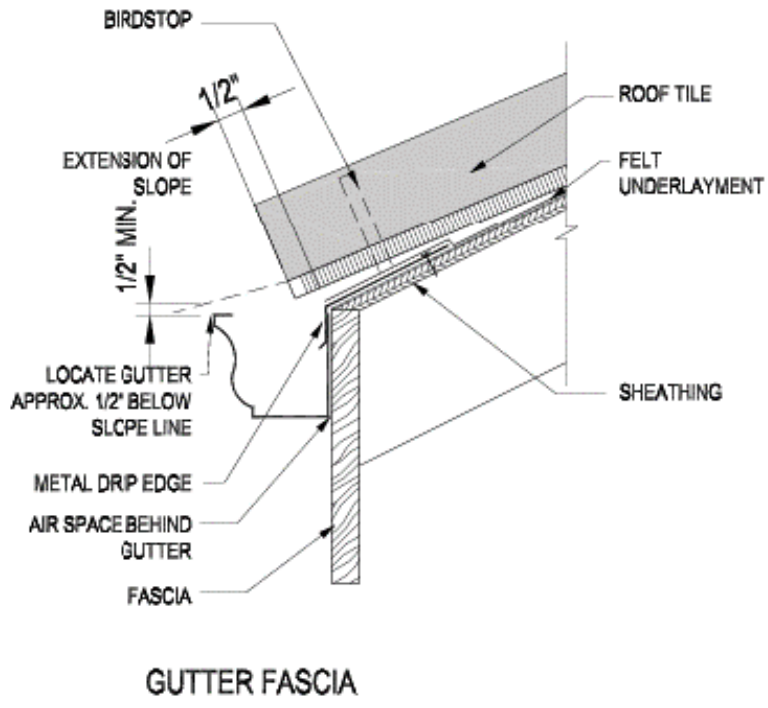

Ventilated flashing at eave:

